

General Waste and Recyclable Waste Storage and Collection for Residential and Commercial Developments

Head of Power

Local Government Act 2009
Corporate Plan 2017-2022
Environmental Protection Act 1994
Environmental Protection (Waste Management) Regulation 2000
Waste Reduction & Recycling Act 2011
Sustainable Planning Act 2009

Objective

The objective of this policy is to establish standards for the storage and collection of general waste and recyclable waste bins in Residential and Commercial developments, which:

- 1) provides an efficient and cost effective general waste and recyclable waste collection service to all residents and commercial operators within the Moreton Bay Regional Council area;
- 2) ensures that all occupants of residential and commercial developments have suitable access to general waste and recyclable waste storage and collection services;
- 3) ensures that on-site general waste and recyclable waste storage provisions, for residential and commercial developments within the Moreton Bay Regional Council area, create minimal impacts to either occupants of the development or adjoining residents;
- 4) ensures that bins are stored in a manner which preserves an acceptable level of visual amenity within and adjacent to residential and commercial developments; and
- 5) ensures that all general waste and recyclable waste bins can be collected in a reliable and safe manner by Council or Commercial general waste and recyclable waste contractors on collection day/s.

This policy is to be used for the control of existing developments and in the assessment of development applications for the imposition of conditions on development approvals in regards to the storage and collection of general waste and recyclable waste bins for residential and commercial developments.

Definitions

Combined Commercial and Residential Multiple Dwelling Developments includes a mix of residential multiple dwellings with commercial developments.

Commercial Developments for the purpose of this Policy includes commercial and industrial developments.

General Waste is waste (anything left over, surplus or an unwanted by-product that can not be re-used or recycled) other than regulated waste. For the purpose of this policy this does not include construction and demolition waste, liquid waste or other hazardous materials.

Industrial (bulk) Bin includes a bin which has a capacity to hold 0.5m³ or greater of general waste or recyclable waste and may include approved static compaction equipment.

Recyclable Waste includes clean and inoffensive waste that is declared by Council to be recyclable waste and which can therefore be re-used or recycled.

Residential Multiple Dwellings see section 1.3.1 of this policy.

Standard General Waste and Recyclable Waste Collection is the weekly collection of general waste from one 120L or 240L wheeled bin and the fortnightly collection of recyclable waste from one 120L or 240L wheeled bin.

Waste Management Program is a program showing details of how general waste and recyclable waste collections are to be managed for the development, including but not limited to storage and collection point locations and design, access for residents and vehicles and other servicing requirements.

Wheeled bin is an approved waste or recyclable waste container as supplied by Council for the purpose of storage and collection of waste or recyclable waste. A wheeled bin has a capacity of up to 240L.

Application

This policy applies to all residential (including residential multiple dwellings) and commercial developments within the defined Waste Collection Area of the Moreton Bay Regional Council area.

Policy Statement

1.0 General Waste and Recyclable Waste Storage and Collection Requirements

1.1 Houses

Each dwelling is required to have a standard general waste and recyclable waste collection. Council will provide all general waste and recyclable waste collections, which includes the supply of wheeled bins. The owners or occupiers of the dwelling are required to provide storage areas for all general waste and recyclable waste bins.

1.2 Duplexes

Each dwelling is required to have a standard general waste and recyclable waste collection. Council will provide all general waste and recyclable waste collections, which includes the supply of wheeled bins. The owners or occupiers of the dwelling are required to provide storage areas for all general waste and recyclable waste bins.

1.3 Residential Multiple Dwelling Developments

1.3.1 Residential Multiple Dwelling Classifications

A residential multiple dwelling development, for the purpose of this policy, is classified as 3 or more residential dwellings on one property. Residential properties that are not strata titled, have only one owner and where there is a common kitchen, dining and recreational area are not classified as residential multiple dwellings for the purpose of this policy. These developments may include:

1. Caravan Parks
2. Relocatable Home Parks
3. Retirement Homes greater than 12 residential units

Developments not classified as a Residential Multiple Dwelling Development under this section are to be classified as a Commercial Development. The Chief Executive Officer shall have the authority to determine if a development is classified as either a residential multiple dwelling or a commercial development, for the purposes of this policy.

1.3.2 Number of General Waste and Recyclable Waste Collections

The owners or occupiers of a residential multiple dwelling development are required to provide storage areas for all general waste and recyclable waste bins. The required specifications and capacity for the storage of general waste and recyclable waste bins (wheeled bins or industrial (bulk) bins) are set out in Council's General Waste and Recyclable Waste Storage and Collections - Technical Guideline.

Council will provide all general waste and recyclable waste collections, which includes the supply of wheeled bins or industrial (bulk) bins as approved by Council, for residential multiple dwellings.

1.3.3 Gated Communities

Gated Communities are to be classified as residential multiple dwellings and as such are subject to the same general waste and recyclable waste collection requirements as residential multiple dwellings.

1.4 Combined Commercial and Residential Multiple Dwelling Developments

1.4.1 Number of General Waste and Recyclable Waste Collections

The owners of a combined commercial and residential multiple dwelling development are required to provide storage areas for all general waste and recyclable waste bins. The required specifications and capacity for the storage of general waste and recyclable waste bins (wheeled bins or industrial (bulk) bins) are set out in Council's General Waste and Recyclable Waste Storage and Collections - Technical Guideline, unless the planning scheme for an area specifies otherwise.

Council will provide all general waste and recyclable waste collections, which includes the supply of wheeled bins or industrial (bulk) bins as approved by Council, for combined commercial and residential multiple dwelling developments.

1.5 Commercial Developments

1.5.1 Number of General Waste and Recyclable Waste Collections

The owners of a commercial development are required to provide storage areas for all general waste and recyclable waste bins. The required specifications and capacity for the storage of general waste and recyclable waste bins (wheeled bins or industrial (bulk) bins) is set out in Council's General Waste and Recyclable Waste Storage and Collections - Technical Guideline.

Either Council (wheeled bins) or a licensed contractor (industrial (bulk) bins) may provide and collect the general waste and recyclable waste bins.

1.6 New Developments

In the planning and construction process for commercial and residential multiple dwelling developments, the developer must ensure that provisions are made for the storage and collection of general waste and recyclable waste bins (wheeled bins or industrial (bulk) bins) in line with the objectives of this policy. New developments include the reconfiguring of a lot and a material change of use as defined in the Integrated Planning Act 1997.

The Developer must submit a Waste Management Program for approval by Council as part of the Development Application. The program must be developed in line with the requirements set out in the General Waste and Recyclable Waste Storage and Collections - Technical Guideline, unless the planning scheme for an area specifies otherwise.

2.0 Public Health Impacts

2.1 Odour, hygiene, vermin

All wheeled and industrial (bulk) bins are to be cleaned internally and externally on a regular basis to minimise odour impacts and the attraction of vermin. A general waste and recyclable waste bin storage area must be located so that odour impacts are minimised for onsite and neighbouring occupants. The lids of all general waste and recyclable waste bins must be shut when they are being stored and when they are placed out for collection.

2.2 Noise

A general waste and recyclable waste bin storage area must be located so that noise impacts are minimised for residents located onsite and within neighbouring premises.

2.3 Visual amenity

Any general waste and recyclable waste bin storage area must be screened so the bin(s) cannot be seen from residential premises or public accessible areas. An adequate number of bins must be provided so all general waste and recyclable waste material is contained within the bins, so the lids can be easily shut.

3.0 Special Services

Council will provide special general waste and recyclable waste collection services for residents that are unable to place their bins at the nominated collection point, due to their incapacity to manoeuvre the bins. Council will assess the requests from residents based on acceptable criteria determined by Council's Chief Executive Officer. The Chief Executive Officer will make a determination whether to approve the request.

4.0 General Information

The responsibility for transferring the bins from within the property to the collection point and returning them promptly to the storage area after collection is the responsibility of the occupants and as such this needs to be considered when designing the development. Council or Council's general waste and recyclable waste collection contractors are not responsible for transferring bins, unless approved by Council. The collection point will be either at the kerbside or at the location nominated in the Waste Management Program as approved by Council's Chief Executive Officer.

The occupiers of residential or commercial premises are required to:

1. ensure that all wheeled and industrial (bulk) bins are removed from the footpath or other point of collection (if not the approved storage location) by the end of the day on which the collection service was performed. The bins are to be returned promptly to the approved storage location; and
2. ensure all wheeled and industrial (bulk) bins are kept clean, tidy and free of any graffiti; and
3. report all damaged, stolen, broken and unserviceable wheeled bins to Council for replacement.
4. report all damaged, stolen, broken and unserviceable industrial (bulk) bins to the relevant contractor for replacement.

5.0 General Waste and Recyclable Waste Storage and Collections - Technical Guideline

The General Waste and Recyclable Waste Storage and Collections - Technical Guideline is an attachment to this policy and is to be authorised by Council's Chief Executive Officer.

Related Documents

This Policy complements and is to be implemented in conjunction with other Council policies, directives and relevant documents published by other agencies including, but not limited to:

Technical Guidelines – General Waste and Recyclable Waste Storage and Collections

Policy: 2150-041 - General Waste and Recyclable Waste Storage and Collection for Residential and Commercial Developments

Review and evaluation

This policy will be reviewed for applicability, effectiveness, and consistency with relevant legislation, Council resolutions, and other Council documents.

A review of this policy will occur by June 2021.

Responsibility

This Policy is to be:

1. implemented by the Manager Waste Services; and
2. Reviewed and amended in accordance with the "Review Triggers" by the Director Engineering, Construction & Maintenance.

Policy: 2150-041		Official Version: A6544443	
Document Control			
Version / Reviewed	Version Adoption (Council meeting / Minute Page) Reviewed (revision comment)	Date	Word version reference
Version 1	Coordination Committee (09/2377)	01.09.2009	A6544443
Version 2	Administrative Correction only: <i>'Head of Power' - legislation.</i> <i>Attachment (Technical Guidelines) added</i>	18.11.2013	A6544443 # (Version 3.0 #4 of PDF)
Version 3	Administrative amendments only: <i>'Head of Power, Review Triggers and Responsibility - position titles'</i> <i>Approved by the Director Engineering, Construction & Maintenance</i>	15.10.2020	A20853259

ATTACHMENT:

General Waste and Recyclable Waste Storage and Collections - Technical Guideline

Application

This document provides a technical guideline for establishing general waste and recyclable waste storage and collection services for residential (including residential multiple dwellings) and commercial developments within the Moreton Bay Regional Council area. The General Waste and Recyclable Waste Storage and Collections - Technical Guideline is to be read in conjunction with Council's Policy "General Waste and Recyclable Waste Storage and Collection for Residential and Commercial Developments".

Objective

This Technical Guideline is to provide detail in the implementation of Council's Policy "General Waste and Recyclable Waste Storage and Collection for Residential and Commercial Developments".

Definitions

See the definitions in Council's Policy "General Waste and Recyclable Waste Storage and Collection for Residential and Commercial Developments"

Guideline Statement

1.0 General Waste and Recyclable Waste Storage and Collections Requirements

1.1 Residential Multiple Dwelling Developments

Where a development consists of residential multiple dwellings, the developer/owners are required to provide general waste and recyclable waste collections in line with the following:

- 1) All general waste and recyclable waste collections will be provided by Council; and
- 2) A waste management program is to be provided by the developer and approved by Council's Chief Executive Officer prior to commencement of construction of the development; and
- 3) The development is required to have sufficient number of general waste and recyclable waste bins to comply with the General Waste and Recyclable Waste Generation Specifications set out in Appendix 5.

A residential multiple dwelling development may use the following types of general waste and recyclable waste collections:

- 1) Industrial (bulk) bins for general waste and recyclable waste, which are provided and collected by Council; or
- 2) Domestic 120/240 L general waste and 120/240L recyclable waste wheeled bins, which are provided and collected by Council; or
- 3) Static compactors for general waste and/or recyclable waste, which are collected by Council; or
- 4) A combination of the above.

1.2 Combined Commercial and Residential Multiple Dwelling Developments

Where a development consists of a mix of commercial operations and multiple residential dwellings, the developer/owners are required to provide general waste and recyclable waste collections in line with the following:

- 1) All general waste and recyclable waste collections will be provided by Council; and

Policy: 2150-041 - General Waste and Recyclable Waste Storage and Collection for Residential and Commercial Developments

- 2) A waste management program is to be provided by the developer and approved by Council's Chief Executive Officer prior to commencement of construction of the development; and
- 3) The development is required to have sufficient number of general waste and recyclable waste bins to comply with the General Waste and Recyclable Waste Generation Specifications set out in Appendix 5.

A mixed commercial and residential multiple dwelling development may use the following types of general waste and recyclable waste collections:

- 1) Industrial (bulk) bins for general waste and recyclable waste, which are provided and collected by Council; or
- 2) Commercial 240 L general waste and 240L recyclable waste wheeled bins for the commercial operation, which are provided and collected by Council; or
- 3) Domestic 120/240 L general waste and 120L/240L recyclable waste wheeled bins for the residential multiple dwellings, which are provided and collected by Council; or
- 4) Static compactors for general waste and/or recyclable waste, which are collected by Council; or
- 5) A combination of the above.

1.3 Commercial Developments

Where a development consists of commercial operations, the developer/owners are required to provide general waste and recyclable waste collections in line with the following:

- 1) A Standard Commercial 240L general waste and 240L recyclable waste collection may be provided by Council; and
- 2) Any Commercial general waste and recyclable waste collections utilising industrial (bulk) bins or static compactors will be provided by a licensed contractor; and
- 3) A waste management program is to be provided by the developer and approved by Council's Chief Executive Officer prior to commencement of construction of the development; and
- 4) The development is required to have sufficient number of general waste and recyclable waste bins to comply with the General Waste and Recyclable Waste Generation Specifications set out in Appendix 5.

A commercial development may use the following types of general waste and recyclable waste collections:

- 1) Commercial 240 L general waste and 240L recyclable waste wheeled bins, which are provided and collected by Council; or
- 2) Industrial (bulk) bins for general waste and recyclable waste, which may be provided and collected by a licensed Contractor; or
- 3) Static compactors for waste and/or recyclable waste, which may be provided and collected by a licensed contractor.
- 4) A combination of the above.

Where hostels, aged and care facilities require general waste and recyclable waste collections for individual residential tenanted dwellings, Council's Chief Executive Officer may determine the number and type of wheeled bins that are required to collect the general waste and recyclable waste materials. Charges will be relevant to the collections provided. See Appendix 5 for details.

1.4 Provision of Collection Services

Council will:

- 1) Ensure that all general waste and recyclable waste wheeled bins or industrial (bulk) bins, which are placed in the agreed location prior to the nominated collection time, are collected; and
- 2) Rate each dwelling/unit for a general waste and recyclable waste collection.

Residents and/or Commercial operators are required to:

- 1) Place their wheeled bin/s in the designated location for collection before 6am on collection day/s; and
- 2) Store their wheeled bin/s in the designated location on days other than collection day/s; and
- 3) Ensure bins are regularly cleaned in an approved bin wash down facility, where applicable.

1.4.1 New Developments

The planning and construction process for residential multiple dwellings and/or commercial developments must ensure that sufficient provision is made for the storage of all general waste and recyclable waste bins on collection day, in a location suitable for collection and at all other times, in an approved storage area.

1.4.1.1 The Developer, in line with the General Waste and Recyclable Waste Generation Specifications set out in Appendix 5,

- 1) must ensure that storage is provided within the development for,
 - a. an appropriate capacity of wheeled bins for general waste and recyclable waste or;
 - b. an appropriate capacity of industrial (bulk) bins for general waste and recyclable waste or;
 - c. an appropriate capacity of industrial (bulk) bins and wheeled bins; and
- 2) must ensure the storage area is not within an enclosed and unvented garage of a unit, but may be within an open sided carport; and
- 3) may have the storage area within one or more common corral/s, but any such corral must be capable of storing sufficient bins for all units within the development, and they must be within a reasonable walking distance of all units within the development served by that facility and the residents must have clear access to all bins in the corral/s at all times.

1.4.1.2 Should the development utilise wheeled general waste and recyclable waste bins, which will be collected at the kerbside, the Developer,

- 1) must ensure that there is sufficient storage on the footpath kerbside for collection of both bins on the waste/recyclable waste collection day without obstructing pedestrian movement along the footpath or driver sightlines at the vehicular access points; and
- 2) must ensure there is sufficient storage along the footpath kerbside to allow the general waste and recyclable waste collection vehicles to freely service each general waste and recyclable waste bin without the driver having to alight from the vehicle; and
- 3) must ensure a minimum space of 1 metre is available for each general waste and recyclable waste bin; and
- 4) must ensure there is sufficient space so that the general waste and recyclable waste bins are not to be stored on the driveway, in front of any other property or in front of any bus stops or the like.

1.4.1.3 Should the development utilise wheeled general waste and recyclable waste bins or industrial (bulk) bins, which will be collected inside the property, the Developer,

- 1) must ensure that the general waste and recyclable waste collection vehicles can enter the internal roads of the development to collect the wheeled bins; and
- 2) must ensure there is sufficient storage along the internal footpath kerbside to allow the general waste and recyclable waste collection vehicles to freely service each general waste and recyclable waste bin without the driver having to alight from the vehicle; and
- 3) must ensure a minimum space of 1 metre is available for each general waste and recyclable waste bin; and
- 4) must ensure there is sufficient space so that the general waste and recyclable waste bins are not to be stored on the internal driveways; and

Policy: 2150-041 - General Waste and Recyclable Waste Storage and Collection for Residential and Commercial Developments

- 5) must ensure the general waste and recyclable waste collection vehicles are able to enter and leave the premises and remain in a forward gear at all times, unless the Planning Scheme for that area allows a Heavy Rigid Vehicle (HRV) to reverse onto a road with a specified road classification; and
- 6) must ensure there are adequate internal turnaround areas to allow a HRV to easily and safely complete a 3 point turn, unless the Planning Scheme for that area allows a HRV to reverse onto a road with a specified road classification. The specification of the height, width, length and turning capabilities of general waste and recyclable waste vehicles are provided in Appendix 4; and
- 7) must ensure that any car parking within the property shall not hinder or obstruct access of the waste or recyclable waste collection vehicles.

1.4.2 Waste Management Program

The developer must provide a waste management program for residential multiple dwellings and/or commercial developments, showing the following:

- 1) Location/s and number of the wheeled bins, where they will be stored and the point of collection.
- 2) Location/s and number of the industrial (bulk) bins, where they will be stored and the point of collection.
- 3) Dimensions of the bin storage area.
- 4) The path the bins are to be taken from any storage area to the collection point. There shall be no steps or obstructions in the path of travel for wheeled bins from the storage area to the collection point.
- 5) Details of the screen storage area if the bins are visible from a public place.
- 6) The access to the premises by a heavy rigid vehicle (HRV) and the path the vehicle will travel on site, including any stopping or turnaround areas.
- 7) Design specifications showing the route of the HRV including turning circles and pavement capacity. The pavement, including turning areas is to be designed and constructed to carry a 30 tonne HRV. An Engineer's Certification must be provided to this effect.
- 8) A safety evaluation is to be provided identifying all hazards to persons and property and how these safety hazards will be managed.
- 9) The location and design of the bin wash down area/s. The wash down area is to be in accordance with Council's current standard for sewerage connections. Plumbing approval must be obtained prior to construction. See also Appendix 3.
- 10) Any additional information required by the Chief Executive Officer to properly assess the development application to ensure compliance with the objectives of Council's Policy "General Waste and Recyclable Waste Storage and Collection for Residential and Commercial Developments"

2.0 Storage Areas – Structural Requirements

2.1 Residential Multiple Dwelling Developments

Subject to the requirements of section 1.0 General Waste and Recyclable Waste Storage and Collection Requirements, the following options listed below are available for residential multiple dwelling storage areas:

Each residential multiple dwelling development is required to have either:

2.1.1 A dedicated general waste and recyclable waste storage area, that –

- 1) is located within the curtilage of the dwelling unit, not including enclosed garages; and
- 2) allows for bins to be moved from the storage area to the collection point without travelling over steps or through dwelling areas; and
- 3) has a hardstand surface (concrete) and the bins are screened or located so they can not be seen from a public place; or
- 4) an alternative solution that is acceptable to Council's Chief Executive Officer.

2.1.2 A centralised bin storage area serving a number of dwelling units that:

- 1) is large enough to store the number of general waste and recyclable waste bins, being industrial (bulk) bins or wheeled bins, equivalent in volume to the appropriate type of development as outlined in Appendix 5; and
- 2) is dedicated for the storage of general waste and recyclable waste bins and associated equipment; and
- 3) is either an external general waste and recyclable waste storage enclosure that complies with section 2.4 or an internal general waste and recyclable waste storage room that complies with section 2.5; and
- 4) allows for 0.2m space around bins for manoeuvrability and cleansing; and
- 5) has a smooth hardstand surface (concrete) that will permit easy bin movement, and
- 6) is fitted with bump rails to prevent steel industrial (bulk) bins from contacting walls; and
- 7) is both a storage area and a collection point when industrial (bulk) bins greater than 1.5m³ are used; and
- 8) is both a storage area and a collection point or is positioned within 20m of the collection point when industrial (bulk) bins of 1.5m³ or less are used; and
- 9) is not located immediately adjacent to living and eating areas of any unit on site or on a neighbouring property; and
- 10) complies with general waste and recyclable waste servicing section 3.0; or
- 11) an alternative solution that is acceptable to Council's Chief Executive Officer.

2.1.3 This section applies to developments where waste chutes are provided.

Waste chutes are provided for the transport of general waste and recyclable waste materials from each residential floor level to the internal general waste and recyclable waste storage room and are -

- 1) accessible for use by all dwelling units on each floor; and
- 2) hygienic and easily serviced; and
- 3) insect and vermin proof; and
- 4) constructed and located to minimise noise, odour and vibration impacts on users, occupiers and neighbours of the property; and
- 5) complies with internal general waste and recyclable waste rooms section 2.5; or
- 6) an alternative solution that is acceptable to Council's Chief Executive Officer.

2.2 Commercial Developments

A storage area is to be provided for all general waste and recyclable waste bins, that shall-

- 1) be large enough to store the number of general waste and recyclable waste bins, being industrial (bulk) bins or wheeled bins, equivalent in volume to the appropriate type of property as outlined in Appendix 5; and
- 2) be dedicated for the storage of general waste and recyclable waste bins and associated equipment only; and
- 3) be either an external general waste and recyclable waste storage enclosure that complies with section 2.4 or an internal general waste and recyclable waste storage room that complies with section 2.5; and
- 4) allow for 0.2m space around bins for manoeuvrability and cleansing; and
- 5) have a smooth hardstand surface (concrete) that will permit easy bin movement; and
- 6) is fitted with bump rails to prevent steel industrial (bulk) bins from contacting walls; and
- 7) is both a storage area and a collection point when industrial (bulk) bins greater than 1.5m³ are used; and
- 8) is both a storage area and a collection point or is positioned within 20m of the collection point when industrial (bulk) bins 1.5m³ or less are used; and
- 9) is not located immediately adjacent to living and eating areas of any unit on site or neighbouring dwelling; and
- 10) comply with general waste and recyclable waste servicing section 3.0; or
- 11) an alternative solution that is acceptable to Council's Chief Executive Officer.

2.3 Combined Commercial and Residential Multiple Dwellings Developments

This section applies where a residential multiple dwelling development is combined with a commercial development.

Each residential and commercial general waste and recyclable waste storage area -

- 1) must be large enough to store the number of general waste and recyclable waste bins, being industrial (bulk) bins or wheelie bins, equivalent in volume to the appropriate type of residential and commercial property as outlined in Appendix 5; and
- 2) must be dedicated for the storage of general waste and recyclable waste bins and associated equipment only; and
- 3) that is either an external general waste and recyclable waste storage enclosure that complies with section 2.4 or an internal general waste and recyclable waste storage room that complies with section 2.5; and
- 4) must allow for 0.2m space around bins for manoeuvrability and cleansing; and
- 5) must have a smooth hardstand surface (concrete) that will permit easy bin movement; and
- 6) must be fitted with bump rails to prevent steel industrial (bulk) bins from contacting walls; and
- 7) must be both a storage area and a collection point when industrial (bulk) bins greater than 1.5m³ are used; and
- 8) must be both a storage area and a collection point or is positioned within 20m of the collection point when industrial (bulk) bins 1.5m³ or less are used; and
- 9) must not be located immediately adjacent to living and eating areas of any unit on site or neighbouring dwelling; and
- 10) must comply with general waste and recyclable waste servicing section 3.0; or
- 11) must be an alternative solution that is acceptable to Council's Chief Executive Officer.

2.4 External General Waste and Recyclable Waste Bin Storage Enclosures

External general waste and recyclable waste storage enclosures shall have -

- 1) bins that are screened from residential and public accessible areas through design and landscaping; and
- 2) a roller door or outwardly opening gates that can be bolted open greater than 90 degrees; and
- 3) if roofed, a minimum ceiling height of 2.4m and be adequately ventilated; and
- 4) if intended to be both a bin wash-down and a storage enclosure, comply with general waste and recyclable waste bin cleansing section 2.6; or
- 5) an alternative solution that is acceptable to Council's Chief Executive Officer.

2.5 Internal General Waste and Recyclable Waste Storage Rooms

Internal general waste and recyclable waste storage rooms shall have -

- 1) doors that are close fitting, self closing and wide enough for industrial (bulk) bin access and manoeuvrability; and
- 2) walls, doors and roof that are constructed and lined with a non-combustible and impervious material with a smooth finish and a fire resistance of one hour; and
- 3) the junctions of walls with floors covered and artificial lighting provided; and
- 4) doors that are rebated with a lock capable of being activated from within the room without a key, at all times; and
- 5) hose-cock and an adequate length of hand hose of minimum internal diameter 12mm that is provided immediately outside the room; and
- 6) unless refrigerated below four degrees Celsius, the room has an approved mechanical exhaust system for ventilation or permanent, unobstructed natural ventilation openings direct to the external air not less than one-twentieth (1/20th) of the floor area. One half of such openings shall be situated at or near the floor level, and one half at or near the ceiling level; and

Policy: 2150-041 - General Waste and Recyclable Waste Storage and Collection for Residential and Commercial Developments

- 7) fitted with automatic sprinklers or other system for the control of fire which meets Australian Standards; and
- 8) fly and vermin proof; and
- 9) smooth flooring that is graded and drained to an approved sewerage connection located external to the general waste and recyclable waste room and as close to the doorway as possible; and
- 10) measures to prevent stormwater and surface water from entering the general waste and recyclable waste storage room; and
- 11) all conduits concealed in the floor, walls or ceilings; or
- 12) an alternative solution that is acceptable to Council's Chief Executive Officer.

2.6 General Waste and Recyclable Waste Bin Cleansing

Cleansing of all general waste and recyclable waste bins must be conducted to minimise impacts on the environment, occupiers and neighbouring properties.

A wash down bay must be installed at the property where:

- 1) industrial (bulk) bins are utilised; or
- 2) one or more centralised general waste and recyclable waste storage areas are provided; or
- 3) bins are provided for a combined commercial and residential multiple dwelling development.

A bin wash down bay shall -

- 1) be incorporated into the general waste and recyclable waste storage area or is located so that general waste and recyclable waste bins can be easily moved to the wash down bay; and
- 2) have a hardstand area suitably drained to an approved sewerage connection; and
- 3) have a hose and cock located within the vicinity of the bay; or
- 4) an alternative solution that is acceptable to Council's Chief Executive Officer

See Appendix 3 for details.

2.7 Size and Type of General Waste and Recyclable Waste Bins

Where a Residential Multiple Dwelling Development utilises wheeled bins, all bins will be of the same size and type unless all of the bins are serviced from outside each individual unit, the bins are stored separately at each unit and the user of the bins can be easily identified by the operator of the collection vehicle.

3.0 Servicing and Manoeuvrability by General Waste and Recyclable Waste Collection Vehicles.

Where general waste and recyclable waste vehicles are required to collect general waste and recyclable waste bins on the property, the developer shall ensure –

- 1) the design specifications for the roadway and pavement is sufficient to carry a heavy rigid vehicle (HRV) with a minimum load capacity of 30 tonne; and
- 2) the turning circles are designed in accordance with AUSTRROADS: design single unit truck/bus (12.5m) template (see Appendix 4 for vehicle specifications). An Engineer's Certification shall be provided to this effect, unless the Planning Scheme for that area or other law allows a HRV to reverse onto a road with a specified road classification; and
- 3) the ability for general waste and recyclable waste collection vehicles to be able to enter and exit the development in a forward direction, unless the Planning Scheme for that area allows a HRV to reverse onto a road with a specified road classification; and
- 4) a turning bowl or a "T" shaped or similar maneuvering area is provided, which allows the vehicle to turn with no more than a three point turn.

Within a building or structure—

- 1) the height clearance must be sufficient to allow for safe travel and lifting for vehicles and bins (see Appendix 2 for bin dimensions and Appendix 4 for vehicle specifications); and
- 2) the grade of access/egress ramps must not exceed 1:12.

4.0 Specialised Equipment and Facilities

Council may require or accept specialised equipment in some circumstances, including—

- 1) general waste and recyclable waste chutes; and
- 2) compaction (static compactor) equipment to minimise storage area.

Compaction equipment may be accepted for the following wastes and recyclable wastes—

- 1) mixed recyclable waste;
- 2) cardboard or paper; and
- 3) general waste - a specialised refrigerated compactor may be required where the equipment is likely to cause a nuisance.

Plans for the installation of compactors must be submitted for the approval of Council's Chief Executive Officer.

5.0 Temporary Bin Storage Area

A developer may provide a temporary bin storage area at the front of the property where either wheelie bins or industrial (bulk) bins can be taken to for servicing on collection day. Approval for a temporary storage area is subject to the following.

5.1 The development is designed to provide a temporary storage area inside the boundary of the premises, such that when the bins are placed for servicing they are:

- 1) clearly separated from car parking bays, loading bays and any other similar areas; and
- 2) located such that
 - a. the general waste and recyclable waste removal vehicle can collect the bin from that point without the need to further move the bin or open any gate and/or screening; or
 - b. the general waste and recyclable waste removal vehicle can safely park and the driver can alight from the vehicle and collect the wheeled or industrial (bulk) bins for servicing;
- 3) positioned to allow unobstructed access to and from the collection point; and
- 4) positioned clear of footpaths and pedestrian access; and
- 5) constructed of a solid concrete base or acceptable equivalent; and
- 6) located in a position where the bin(s) can reasonably be expected to remain stationary when not being collected i.e. positioned on a level pad; and
- 7) not positioned in front of shop entrances or other residential premises; and
- 8) not blocking the vision of vehicles using the roadway or entering and exiting the property; and
- 9) positioned such that the servicing vehicle does not impede traffic flow during servicing; and
- 10) capable of being collected without the need for the collection vehicle to reverse; and
- 11) not situated within 20 metres of the turning point of an intersection (including opposite a T bar intersection) or roundabout;

Policy: 2150-041 - General Waste and Recyclable Waste Storage and Collection for Residential and Commercial Developments

- 5.2** All driveway entries which would reasonably be expected to be driven on by general waste and recyclable waste collection vehicles must be designed and constructed of industrial strength standards for a HRV of a minimum 30 tonnes and in compliance with specifications in Appendix 4. An Engineer's Certification shall be provided to this effect. The property owner must provide indemnification to Council's general waste and recyclable waste collector against potential injury to the public and damage to underground services or driveway entry.
- 5.3** The industrial (bulk) bin haulage route, from the permanent storage point to the temporary storage point, shall be:
- 1) devoid of steps or steep rises (including speed bumps); and
 - 2) allow adequate space for manoeuvrability of industrial (bulk) bins; and
 - 3) the grade of access/egress ramps must not exceed 1:12.
- 5.4** Where a general waste or recyclable waste collection vehicle is required to park while the driver exits the vehicle to collect the general waste or recyclable waste bins from a temporary bin storage area, the developer is required to provide a parking area which:
- 1) allows the collection vehicle to easily park without affecting the normal flow of traffic in that area; and
 - 2) is adjacent to the temporary bin storage area; and
 - 3) does not interfere with vehicles entering or exiting the property or any other property.

The developer is required to provide details in the Waste Management Program to be submitted to Council for approval.

Appendix 1 – Wheeled Bin Dimensions Guideline

Nominal volume: 240 litres
Net weight: approx 10 kg
Max load: 45 kg
Permitted total weight: 55 kg

A 1150 mm B 990 mm C 700 mm
D 800 mm E 650 mm F 400 mm
G 550 mm

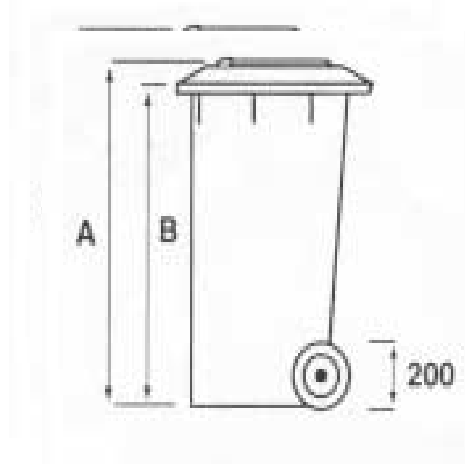
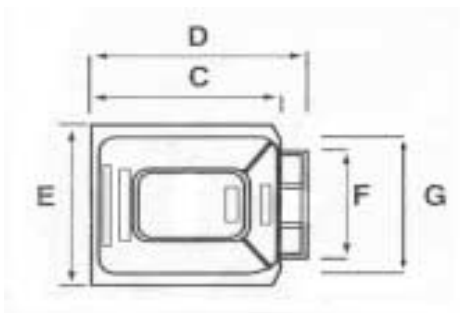

Contact Council for confirmation of bin dimension as bin dimensions may change with different model bins.

Appendix 2 – Industrial (bulk) Bin Dimensions Guideline

Industrial (bulk) Bin Indicative Dimensions

	Industrial (bulk) Bin	Industrial (bulk) Bin	Industrial (bulk) Bin	Industrial (bulk) Bin	Industrial (bulk) Bin
Capacity	1.1m ³	1.5m ³	2.0m ³	3.0m ³	4.5m ³
Height	1,465mm	910mm	865mm	1,225mm	1,570mm
Depth	1,070mm	905mm	1,400mm	1,505mm	1,605mm
Width	1,360mm	1,810mm	1,830mm	1,805mm	1,805mm



Low Noise 1.1m³ Industrial (bulk) Bin with rubber wheels – suitable for unit and resort situations

NB: The Low Noise 1.1m³ Industrial (bulk) Bin collection is only provided in some areas of the Moreton Bay Regional Council area.

Appendix 3 – Storage Guidelines for Wheeled Bins

RECOMMENDED DESIGN GUIDELINES FOR BIN WASH / STORAGE AREAS

Figure A – EXAMPLE ONLY MGB Storage Area (8 MGBs)

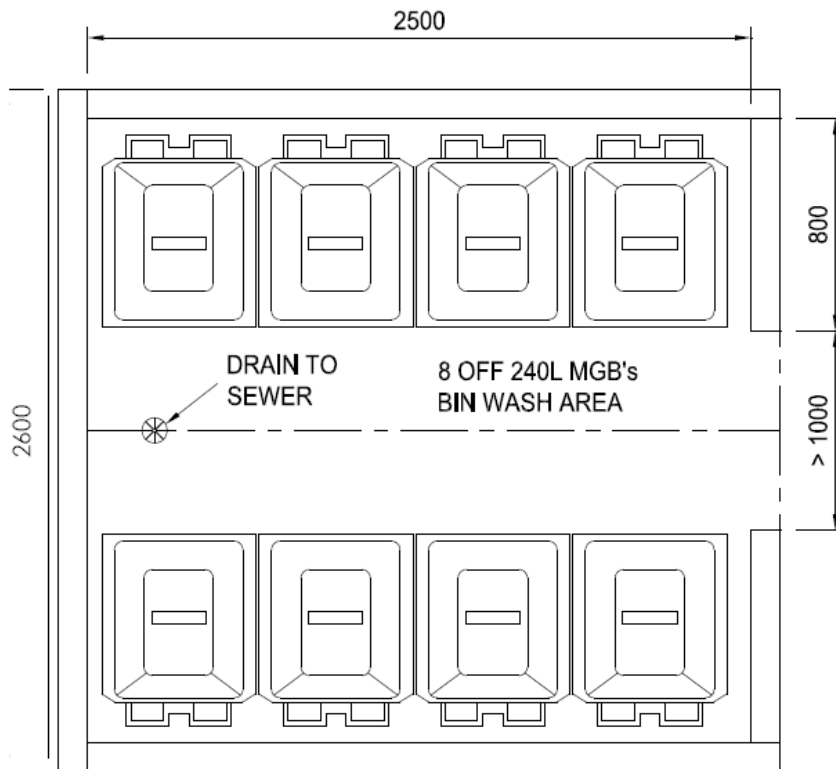

Figure B; A bunded bin wash area in a roofed bin enclosure, which is drained to sewer via a drain. Bund is no more than 100mm in height and drain to sewer is roofed.



Advisory note - Washing bins within bunded areas

240 litre bins should be tipped on their side and washed out to the bunded drain. Industrial (bulk) bins should be wheeled over the bunded area and washed out by removing the plug from the base of the bin.

NB: Plumbing Approval must be obtained prior to construction.

Appendix 4 – General Waste and Recyclable Waste Collection Vehicle Specifications

Side loading collection vehicle

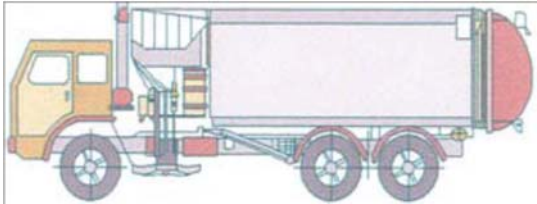

Front loading collection vehicle



Design Vehicle Dimensions

Vehicle Class	Overall Length	Design Width	Wheel Base	Design Turning Radius	Swept Circle	Side Loader Recyclable Waste Vehicle Clearance Height	Front Lift Clearance Height
HRV *	12.50 m	2.50 m	6.60 m	12.50 m	27.80 m	4.6 m	6.10 m

* Dimensions for these vehicles conform to HB 72

Appendix 5 – General Waste and Recyclable Waste Generation Specifications

TYPE OF DEVELOPMENTS	ESTIMATED GENERAL WASTE GENERATION	ESTIMATED RECYCLABLE WASTE GENERATION	NOTES ON THE USE OF BIN TYPE
MULTIPLE UNITS (RESIDENTIAL ONLY) <ul style="list-style-type: none"> 1-2 bedroom 3 bedroom and above 	120L/dwelling/week 120L/dwelling/week	60L/dwelling/week 60L/dwelling/week	
SHARED RESIDENTIAL <ul style="list-style-type: none"> Backpacker accommodation Boarding/Guest house Caravan Parks Relocatable Parks 	40L/occupant/week 60L/occupant/week 60L/occupant/week 60L/occupant/week	20L/occupant/week 20L/occupant/week 20L/occupant/week 20L/occupant/week	
OFFICE BUILDING	10-30L/100m ² /day	20-40L/100m ² /day	
HOTELS/MOTELS/CLUBS <ul style="list-style-type: none"> Residential portion Dining areas Licensed bar area 	5-10L/occupancy/day 50L/100m ² /day 50L/100m ² /day	1L/occupancy/day 10L/100m ² /day 20L/100m ² /day	Allow for waste oil storage Allow for baling of paper and cardboard*
RETAIL FOOD PREMISES <ul style="list-style-type: none"> Butcher shop Delicatessen shop Fish & seafood shop Fruit & vegetable shop Restaurant/Café Take-away food shop Supermarket Shopping Mall 	90L/100m ² floor area/day 120L/100m ² floor area/day 90L/100m ² floor area/day 240L/100m ² floor area/day 5L/1.5m ² floor area/day 120L/100m ² floor area/day 100-300L/100m ² floor area/day Combination to suit development	Variable Variable Variable 120L/100m ² /day 2L/1.5m ² /day Variable 100L/100m ² /day Combination to suit development	Allow for waste oil storage Allow for waste oil storage Allow for waste oil storage Allow for composting* Allow for baling of paper and cardboard* Allow for waste oil storage Allow for baling of paper and cardboard* Allow for waste oil storage
OTHER RETAIL PREMISES <ul style="list-style-type: none"> Shop less than 100m² floor area Shop more than 100m² floor area Showroom 	25L/100m ² floor area/day 50L/100m ² floor area/day 40L/100m ² floor area/day	25L/100m ² /day 50L/100m ² /day 10L/100m ² /day	Allow for baling of paper and cardboard* Allow for baling of paper and cardboard* Allow for baling of paper and cardboard*
SERVICE PREMISES <ul style="list-style-type: none"> Hairdressers/Beauty salons Commercial 	60L/100m ² floor area/day 10L/100m ² floor area/day	Variable 10L/100m ² /day	Wastes from canteen are additional*
INDUSTRIAL PREMISES <ul style="list-style-type: none"> Warehouse Factories 	50L/100m ² floor area/day 60L/100m ² floor area/day		

* Consider allowing additional space for storage of extra bins to separately store either organic waste or other recyclable waste in the future.

Review Triggers

This Technical Guideline is reviewed internally for applicability, continuing effect and consistency with related documents and other legislative provisions when any of the following occurs:

1. The related documents are amended.
2. The related documents are replaced by new documents.

Notwithstanding the above, this Technical Guideline will be reviewed at least once every two years for relevance and to ensure that its effectiveness is maintained.

Responsibility

This Technical Guideline is to be:

- 1) Implemented by the Manager Waste Services; and
- 2) Reviewed and amended in accordance with the "Review Triggers" by the Manager Waste Services.